

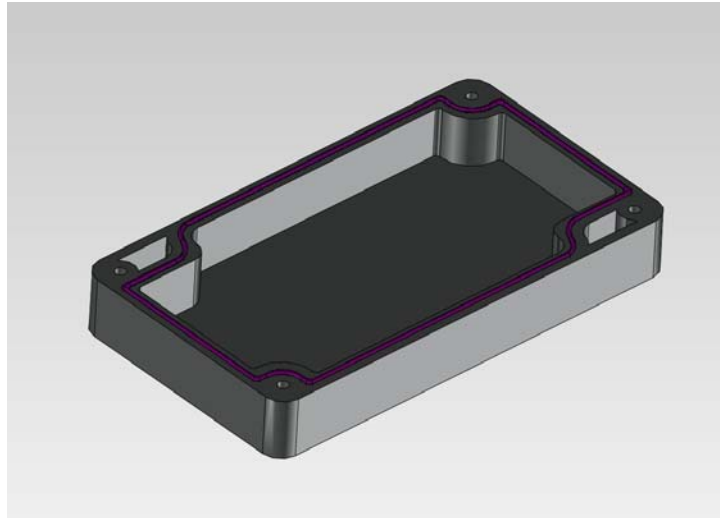

CS67-110x80x45 CASE ASSEMBLY INSTRUCTIONS

- A) The silicone gasket comes pre-installed in the cover.



- B) Align the cover with the base. Insert four screws (provided) into the corner holes. Tighten the screws evenly to 7inch-lb torque. **DO NOT OVERTIGHTEN.**

