

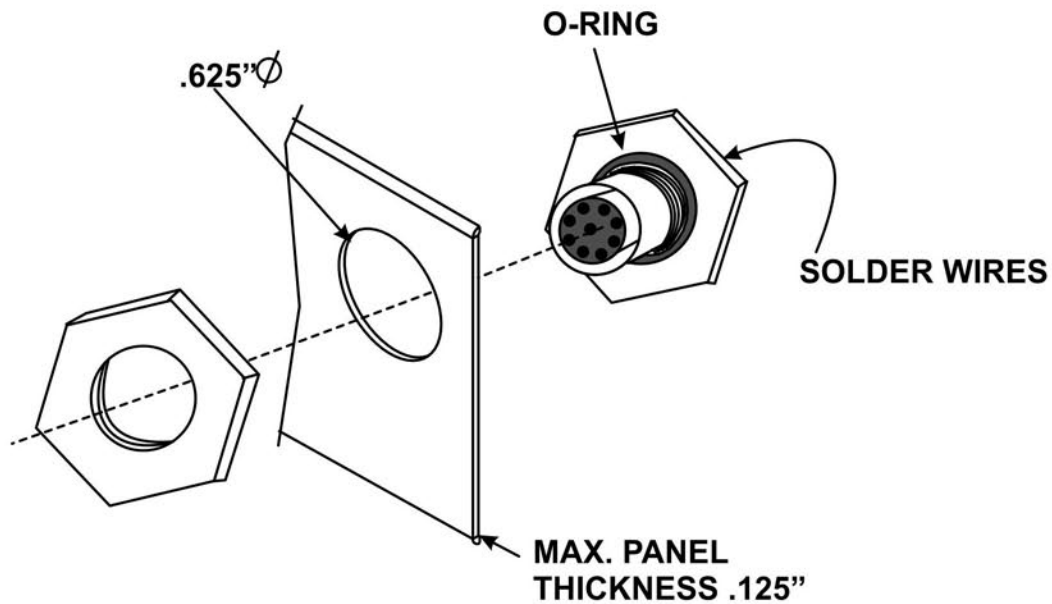

VIDEO
PRODUCTS
INCORPORATED

1275 Danner Drive Aurora, Ohio 44202
Tel: 330-562-2622 Fax: 330-562-1999
www.vpi.us

VPI P/N: M12-8PWTP-PS



Installation:

1. Strip wires for insertion to connector and tin.
2. Solder wires to connector terminals with soldering iron
3. Remove nut from connector, insert connector through .625 inch diameter opening in panel, re-attached nut to connector on other side of panel.
4. Tighten nut to connector. Torque nut to 9 in. lb. with 18mm wrench.