

1394 4P MALE

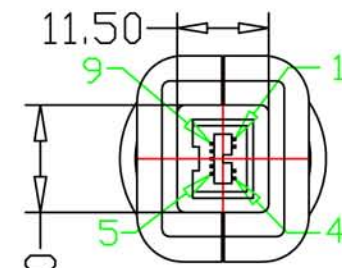
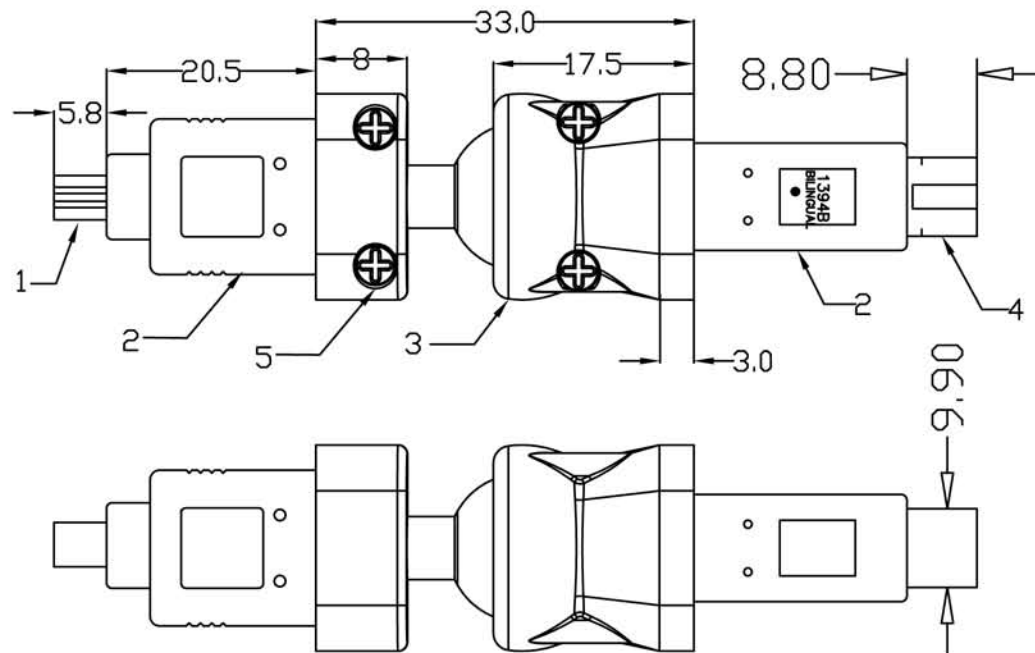

1394 9P

ELECTRICAL PROPERTIES:

1. 100% OPEN SHORT MIS-WIRE TEST
2. Contact Resistance: 1ohm max
3. Insulation Resistance: 20Mega ohm MIN
4. Hi-Pot: 500V DC/10ms

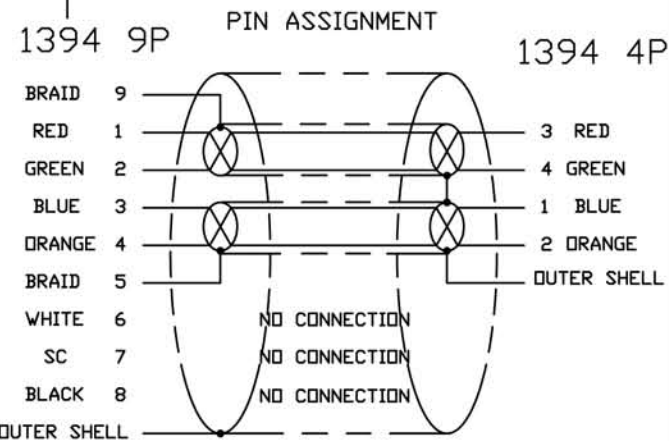

5	4#40 THUMB SCREW COLOR IN BLACK	4	PCS
4	1394 9P BILINGUAL BLACK PASTERN CONNECTOR	1	PCS
3	RETRACTABLE MADE OF ABS SHELL	1	PCS
2	P.V.C MOLDING 55P COLOR: BLACK		
1	1394 4P MALE SOLDER MOLDED TYPE	1	PCS
NO.	DESCRIPTION	Q'TY	UNITS
A		06/05/02	
REV.	DESCRIPTION	DATE	

UNLESS OTHERWISE SPECIFIED TOLERANCE		
ANG.	±5°	
0.	±0.5	
.0	±0.3	
.00	±0.2	
SCALE: NONE	UNIT: mm	
DRAWN	06/05/02	DRAWN NAME:
CHECKED		
APPROVED		PRODUCT NO.
SIZE A4	REV. A	FILE NAME:



1275 Danner Drive Aurora, Ohio 44202
 Tel: 1-800-626-7801 Fax: 330-562-1999
 www.vpi.us sales@vpi.us