

VPI P/N USB2-AB-DRA-xM-K

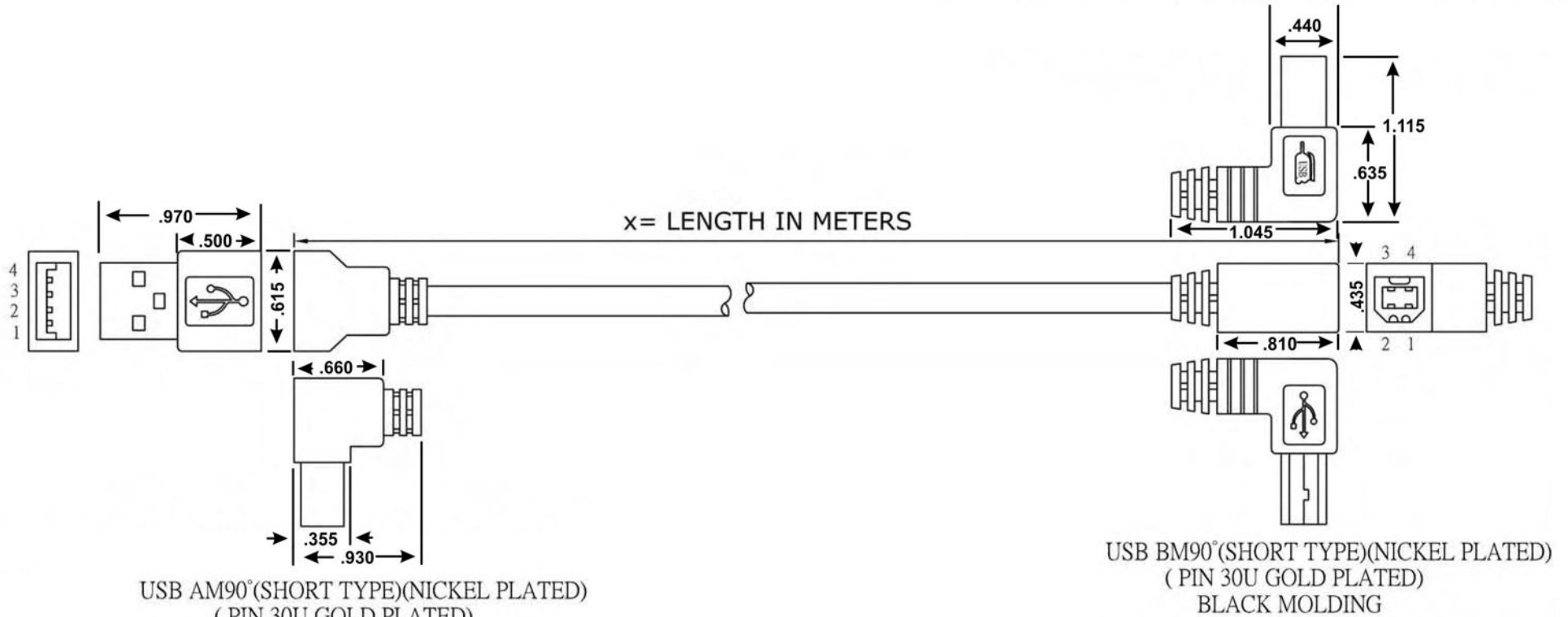

NOTE:

1. CABLE:UL2725 2.0REV,AL+B,28#*1P+24#*2C,OD=4.2mm,BLACK PVC JACKET.(AM)
2. LENGTH:L.
3. CONNECTOR:USB AM*1PCS(WHITE INSULATOR),USB BM*1PCS(WHITE INSULATOR)(PIN 30U GOLD PLATED)
4. MOLD:BLACK MOLDING
5. CONTACTS:

USB AM	1	2	3	4	64
USB BM	1	2	3	4	64
	RED	WHITE	GREEN	BLACK	BRAID
		#28	#28		
		PAIR			

WHITE/GREEN PAIR...28AWG ,
RED/BLACK...24AWG

6. OPEN/SHORT TEST: 100% TEST.

INSULATION:5M.

7. RoHS Compliant

Units: Inches

VPI VIDEO
PRODUCTS
INCORPORATED

1275 Danner Drive Aurora, Ohio 44202
Tel: 330-562-2622 Fax: 330-562-1999
www.vpi.us